

SMARTFLOW®

Pressurized Hot Water Flowmeter, 1/2"

Installation and Operating Instructions

Applies to: HWF4-□-□□, HWF4B-□-□□

General

The Smartflow Pressurized Hot Water Flowmeter provides visual indication of flow in gallons or liters per minute depending on the model. The ball indicator, rests in a groove and is separated from the process by a stainless steel plate. A vane with attached magnet sits inside the process. The ball tracks with the magnet in the process to indicate the rate of flow etched into the flowmeter cover.



Specifications

Flow Range 0 to 6 GPM or 5 to 22 LPM
 Connection size 1/2"NPT or BSPP
 Max. Temperature 400°F (204°C)
 Max. Pressure 250psi (17.2bar)
 Flow Accuracy ±10% of full scale

Component Materials

Body Stainless Steel
 Sensing Vane Stainless Steel
 Hinge Pin Stainless Steel
 Torsion Spring Stainless Steel
 Window Glass
 Gasket Silicone

Installation

The flowmeter is line-mounted without additional support.

1. For best results, install the flowmeter with 10" of straight pipe before the inlet of the flowmeter, and 5" of straight pipe after the outlet of the flowmeter.
2. Use a pipe thread sealant compatible with the maximum operating temperature and process fluid.
3. Observe the direction of flow as etched into the cover plate. It is necessary to install the flowmeter in the correct flow direction.
4. Install the flowmeter so that the cover plate is horizontal or vertical. Text should be right-reading. Do not install this flowmeter upside-down or tilted at an angle.

Warning!

Pressurized hot water cooling applications pose a serious personal injury hazard. Use extreme caution, protective clothing, or shielding around the system to minimize risk to personnel and nearby equipment.

Any liquid system offers the potential for accidental leakage. Leakage onto electrical or computer equipment could result in costly damage or personal injury. Do not locate piping systems where leakage might damage equipment or pose personal injury hazards. If it is impossible to avoid piping in such locations, use shielding to protect equipment and personnel.

Replacement Parts List

Item	Factory Part Number
Cover Plate.....	HFB-50-60
Window	HFW-50
Steel Ball.....	HFSB-156
Isolation Plate.....	HFFR-50
Gasket	HWFG-50
Hinge Pin	FHP-2000
Vane.....	FV-2000
Spring.....	FSP-80
Magnet	HFMG-4000
Optional Temperature Gauge (0 to 600°F)	FMT-4-A

Cleaning (isolation plate groove)

Occasional cleaning of the groove for the flow indication may be needed to maintain proper function of the flowmeter.

1. Allow the flowmeter to cool sufficiently for safe handling.
2. Remove the four cover plate screws.
3. Carefully remove the glass window and steel ball. The glass window will break if dropped.
4. Clean residue from the pocket, groove, and ball, so the ball will roll freely in the groove. It is not necessary to remove the isolation plate.
5. Roll the steel ball in the groove until it is held in position by the magnet. Replace the window and cover plate.

Cleaning (magnet)

A new gasket is required for this operation. Metal fines may collect on the magnet and over time, impair the function of the flowmeter.

1. Remove the four cover plate screws. Remove the window and steel ball. Be careful handling the window, it is glass and will break if dropped.
2. Remove the eight screws attaching the isolation plate. Remove the isolation plate. Discard the gasket.
3. Pull the vane, hinge pin and spring out together to observe how they are assembled. It is not necessary to disassemble these parts.
4. Clean the magnet with a cloth or paper towel. Wipe the residue from the magnet being careful not to loosen it. Do not use compressed air to clean off the magnet.
5. If necessary, assemble the pin through the vane and spring. The spring should be located directly in the center of the vane. The short leg of the spring should rest against the vane, on the side with the magnet. The long leg of the spring will be against the flowmeter body after assembled. The pin, spring, and vane assembly drop into a hole in the bottom of the flowmeter body. The movement of the vane assembly can be tested for proper movement before installing the isolation plate.
6. Install a new gasket and place the isolation plate onto the flowmeter body. Make sure the hole in the isolation plate and the pin line up correctly. If they are not positioned correctly, damage to the flowmeter could occur. Tighten screws in a crossing pattern to properly seat the gasket.
7. Clean all the debris and residue from the pocket, groove, window, and ball so that the ball rolls freely in the groove.
8. Roll steel ball in the groove until it is held in position by the magnet. Replace window and cover plate.

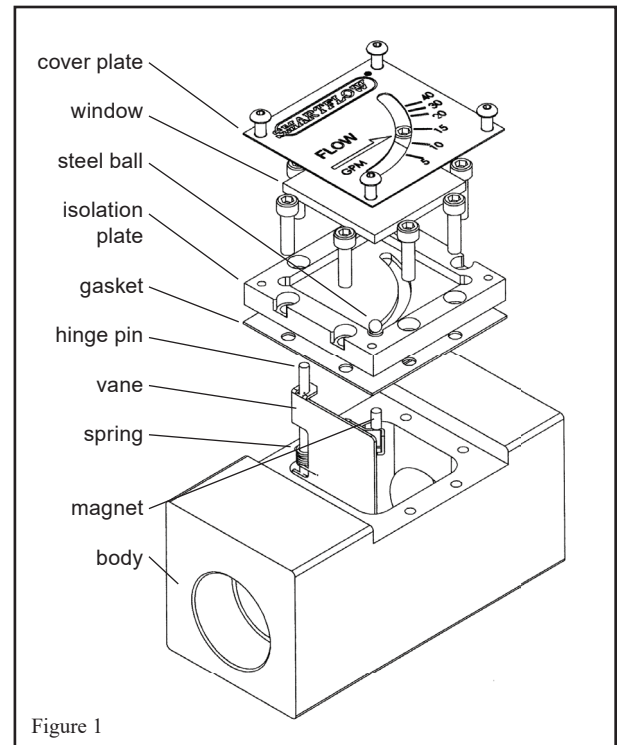

Figure 1

Limited Warranty

Seller warrants that Smartflow® products supplied will conform to the description stated in published literature, and that the product will be of standard quality. The seller warrants manufactured components for 90 days. This is the sole warranty made by Seller with respect to this product. Seller expressly disclaims any other express or implied warranties, including, but not limited to, the implied warranty of merchantability and the implied warranty of fitness for a particular purpose.

Seller shall not be liable for any cost or damages, whether direct, incidental or consequential, including, but not limited to, any injury, loss or damage resulting from the use of this product, regardless of whether any claim for such cost or damages is based on warranty, contract, negligence, tort or strict liability. The sole liability of Seller is limited to repairing or replacing this product.

This warranty shall not apply to any products that have been repaired or altered by anyone other than Seller. The warranty shall not apply to any products subject to misuse due to common negligence or accident, nor to any products manufactured by Seller which are not installed or operated in accordance with the printed instructions of Seller or which have been operated beyond the rated capacity of the goods. Seller states that the product's useful safe life is 5 years. Actual life may vary widely depending on operating environment such as temperature, pressure, and chemical exposure.